



SPARKLINE WELDERS

Welding Machines and Tables Manufacturer

ARC WELDING TABLE

WITH POSITONER

MODEL : ARC TABLE SLW



Welding Fume /Dust Extraction Table with Cartridge Filter , Automatic Filter Cleaning System with Timer Controller and Control Panel

- Clamping and Holding KIT to be Provided for POSITIONING THE Jobs as below for welding
 - a) **Square Tube Framing**
 - b) **Round Tube Framing**
 - c) **I - Beam Framing**
 - d) **Sheet metal box**
 - e) **Plates for welding in LAP joint, Butt joint and T-joint Positions**

Features:

- Welding Table should be with 16 mm Holes in GRID pattern , Suitable for 2 Dimensional Fixture for Holding Jobs.
- There are number of Holes of Diameter 16 mm in Grid form of 50 mm x 50 mm
- Welding Table should be made up of High Quality Material and with Precise Finish on the TOP.
- Welding table must be latest with easy to use Modular Fixturing System
- Welding table must be supplied with modular jigs & fixtures for welding of different jobs
- Suitable for Holding and Positioning Different types of Welding Jobs ,using wide range of clamping accessories.
- It must be highly accurate system to HOLD the JOB and Fix its position for Welding.
- After welding , the JOB should be removed easily and fast in order to replace the new job.
- Welding Table with Holding Accessories is used for faster, easier, efficient, accurate production line.
- Accessories are quickly changeable so it reduces the SET up time of the JOB for welding.
- TOOL BOX with Door to Keep all the Items of this Table to be Provided below the Table TOP.

ARC Welding Table Dimensions

Length =1200 mm,
Width =1200 mm,
Height = 750 mm

- ARC WELDING TABLE is of Heavy Duty M.S. Structure with Angle 35 x 35 x 5 mm
- Welding Table Top is made of High Grade Thick M.S. Material with 16 mm Holes in Grid pattern of 50 mm x 50 mm
- Welding Table is Provided with suitable GTAW ,GMAW welding Gun Holder.
- Welding Table is with suitable KIT of JIGs / Fixtures/ Clamps for clamping the Job as required for Welding.
- To make Different types of welding jobs a KIT is provided to make one job at a time
- The ARC Welding Table has Welding partition mounted on TOP of the Table having Removable Frame on Three sides of the Table with Partition height of 580 to 620 mm
- All JIGs/Fixtures/Clamps can be inserted into any hole on the table for quick and accurate Holding and mounting the Job on the Table.
- KIT of VARIOUS CLAMPS and ACCESSORIES SET to make Welding Jobs is as mentioned below (Quantity of each item will be supplied as per requirement to make one job at a time)

KIT of JIGs / Fixtures / Clamps suitable for welding table

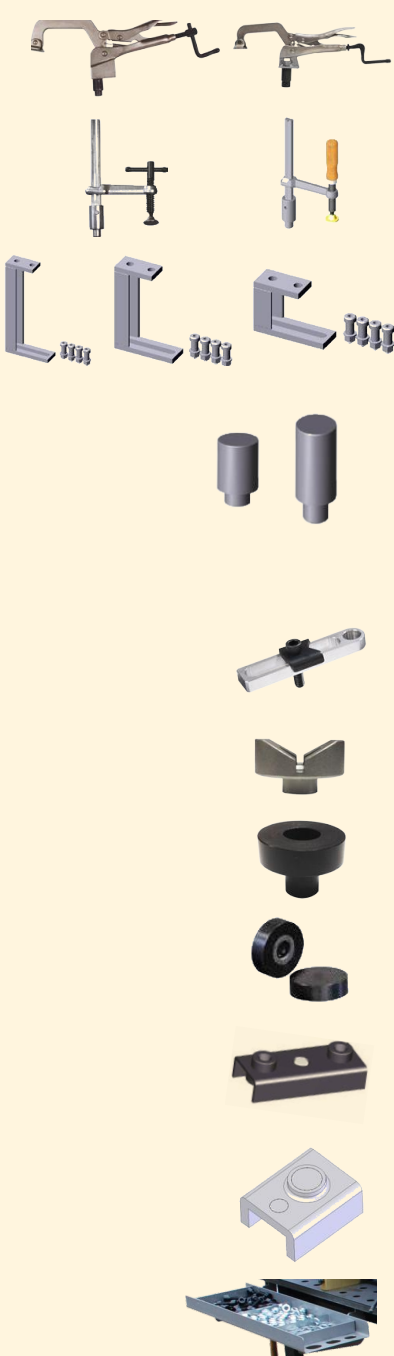

- **Table Mount C-Clamps:** Insert into any hole on the tabletop for Quick Pushdown Clamping Holding and mounting the job on the table.
- **Insert type Clamps :** Insert into any hole on the tabletop for fast and easy Clamping and Holding the job on the table.
- **Stop and Clamping Squares :** This is to support the job vertically, can be used to elevate job. Specially used for various Fit up applications in welding Sheet metal box , vertically mounted pipes / plates welding.
- **STOPPERS :** This Stoppers are used for locating , and convenient positioning the job on the table
(a) Stopper (Short= 25 mm)
(b) Stopper (Long= 50 mm)
- **D-Stop Bars :** It fixes the Job Location and Position effeciently and then with the use of different clamps the Job is fixed / removed from the table. This are used with Threaded adeptors.
- **V-Blocks :** It is used for fixing and aligning the Round parts on table
- **V-Spacer :** It is used for mounting V blocks for elevated pipe jobs on the table
- **Magnetic Rests:** It is to be Place anywhere on the table to hold, elevate and level the job.
- **Threaded Adaptors:** Mount underneath tabletop to convert any table hole to an M10 threaded hole for fixing the jig and fixtures on table .
- **Magnetic Plug :** This can be placed anywhere on the table to elevate and level the job specially used in sheet metal box welding to hold sheet vertically.
- **Removable Tool and Weld Gun Tray with TIG and MIG Gun Holder**

Note: The above accessories are to be used in different combinations as per the job to be clamped on the table.

Accessories:

- **Anti spatter POT, Oil can, Brush for cleaning the Holes & Allen Keys and Spanner Set to Fix the Jigs and fixtures**

LIST OF JOBS



1. Square Tube Framing
2. Round Tube Framing
3. Square & Round Tube Framing
4. I-Beam Framing (Angle & Strip Framing)
5. Sheet Metal Box
6. LAP Joint
7. Butt Joint
8. T - Joint

Job No. 1

Square Tube Framing

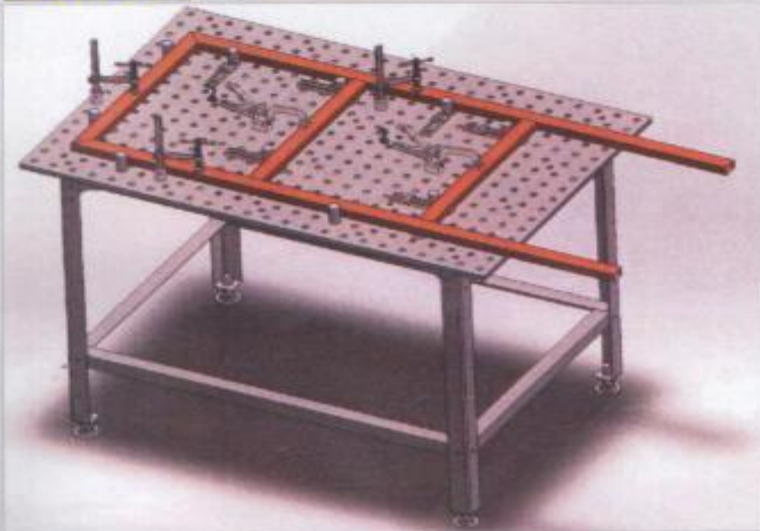

Job No. 2

Round Tube Framing

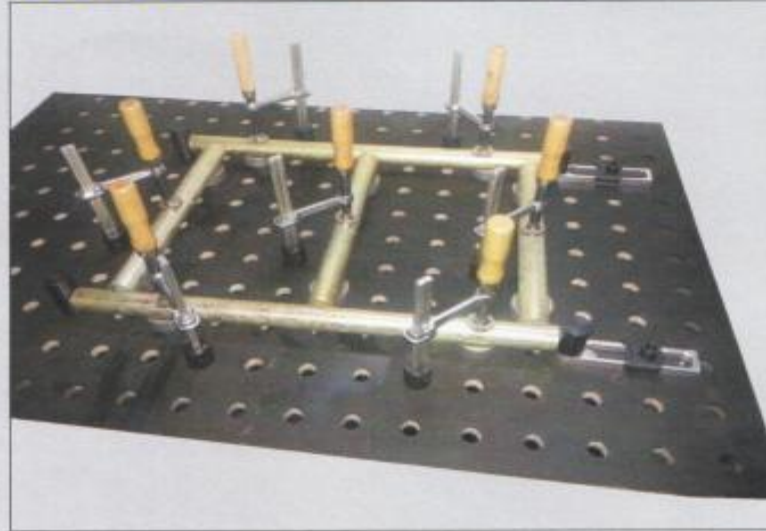

Job No. 3

Square & Round Tube Framing

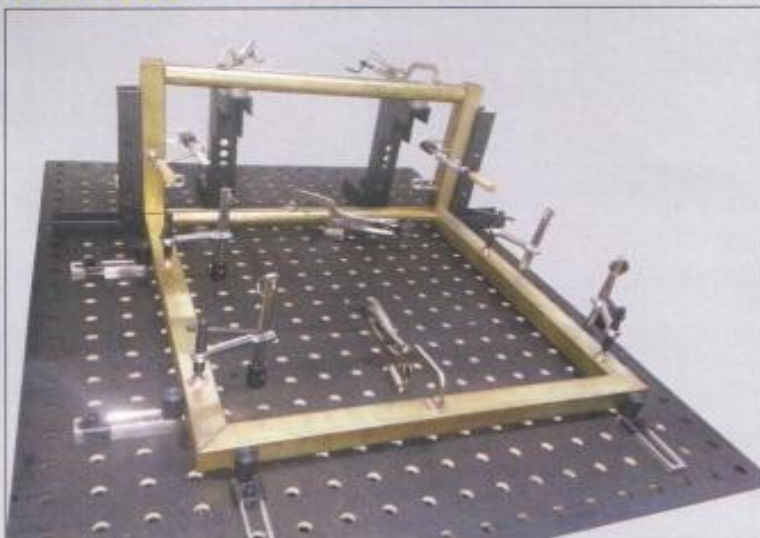

Job No. 4

I - Beam (Angle & Strip Frame)

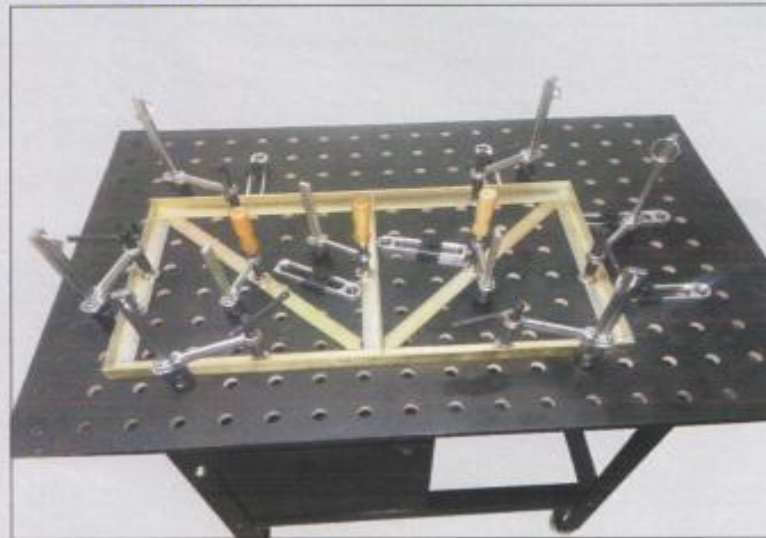

LIST OF JOBS



Job No. 5

Sheet Metal Framing



Job No. 6

LAP Joint



Job No. 7

BUTT Joint

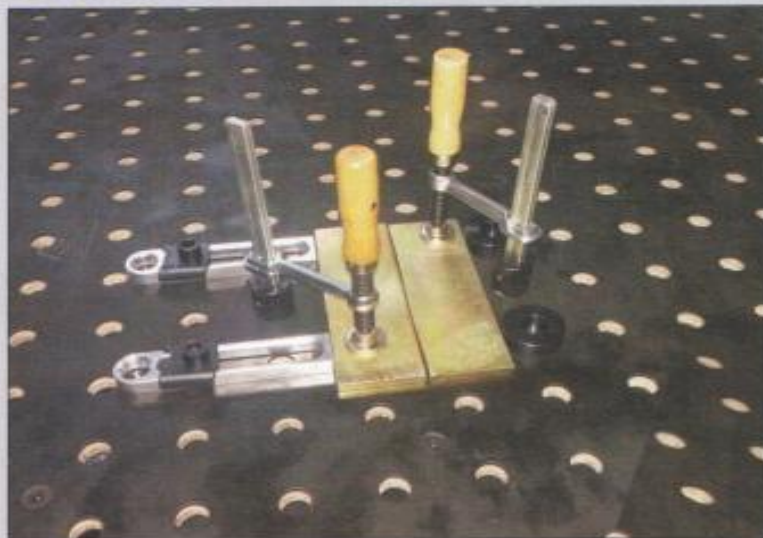

Job No. 8

T - Joint

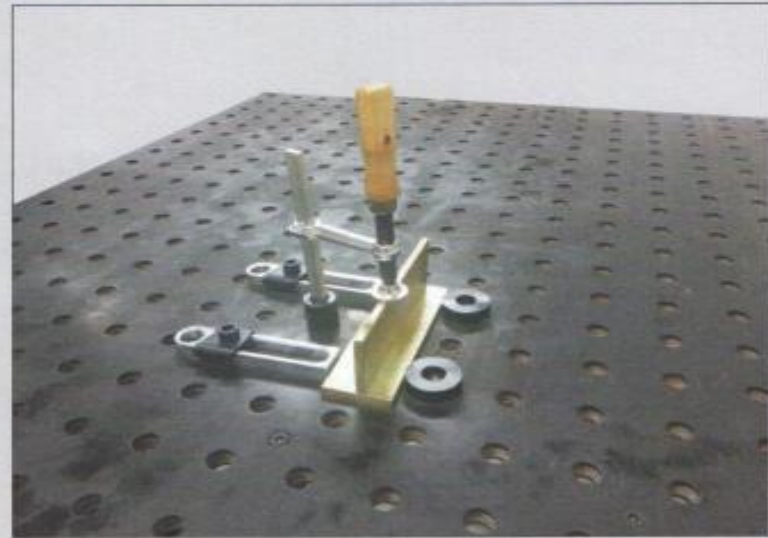

In view of continuous Development, We reserve the rights to modify the design, specifications and or dimensions without notice.

SPARKLINE WELDERS

Works : 7 & 8. Noble Ind. Estate No. 2, Navghar, Vasai (E) - 401 210 Dist. Palghar, (MAH) Tele : 08080027775
Office : 1404,'B' Wing, SUNMIST HUBTOWN ,Sai Wadi, N.S. Phadke Marg, Andheri (East), Mumbai - 400 069. (MAH)
Phone : 022-2683 1777 TeleFAX: 0250 2391452 Email : sparkline78@gmail.com • Visit us : www.sparklinewelders.com